

Citymaster 650 1470.15
9.0.1 Yanmar Engine 3TVN 88C-KHW

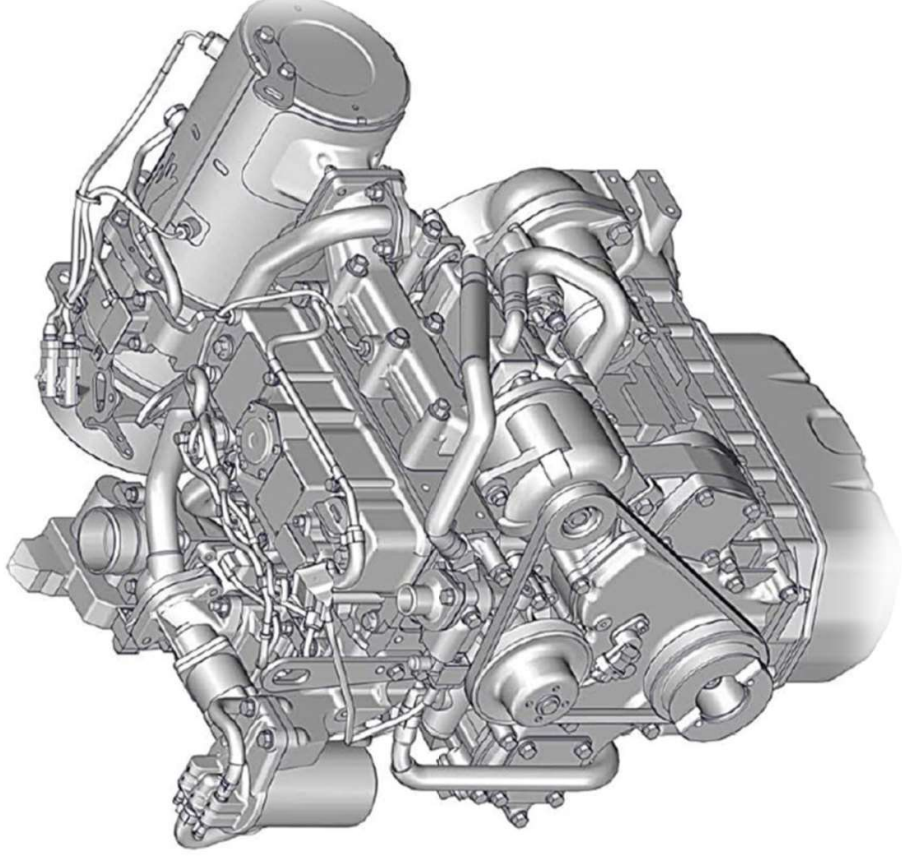

Note: This document is used to provide an overview of the system. For diagnosis and repair work on the Yanmar engine, it is absolutely necessary that the Yanmar Diagnostics software, error message list and the workshop manual are available.

Citymaster 650 1470.15

9.0.1 Yanmar Engine 3TVN 88C-KHW



Inhalt/ Contents	Seite /Page
Technical data Yanmar engine 3TVN 88C- KHW	3- 4
Engine maintenance Yanmar engine 3TVN 88C- KHW	5- 15
Attachment parts on the engine	17- 19
Mounting position of sensors of the electronic engine control unit	20
Installation position of exhaust system components and sensors	21- 24
Installation position of components and sensors of the high pressure injection system (common rail)	25 - 27
Electrical components on Yanmar engine	28- 31
Diesel particulate filter and particulate filter regeneration	32- 34
Funtion of Major Engine Components	35- 36
Injectors	37
Crankshaft sensor and camshaft sensor	38

Citymaster 650 1470.15

9.0.1 Yanmar Engine 3TVN 88C-KHW

Technical data



	Technical Data	Remarks
Manufacturer	Yanmar	
Engine Typ	3TNV88C-KHW Common Rail Engine with DPF	
Displacement	1642 ccm	
Power	25.5 kW at 2600 engine revolutions	
Engine Speed	Max. 2630 rpm	
Bore - Stroke	88 X 90 mm	
No. Of cylinders	3	
Valves per Cylinder	2	
Firing Order	01.03.2002	Cylinder 1 at flywheel side
Rotation Direction	Counterclockwise	View from flywheel side
Engine oil pressure- idling speed	0,6 bar	
Engine oil pressure- 2700 rpm	3,4 – 5,4 bar	
Compression	33 – 35 bar at approx. 250 1/ min	
Wear Limit	26 – 28 bar at approx. 250 1/min	
Difference / per Cylinder	2- 4 bar pro Zylinder	2- 4 bar pro Zylinder
Engine Oil Qty.	Approx 6,7 Liter	
Engine Oil Specification	Spezifikation: ACEA E6, API CJ-4, CAT ECF-3	E.g. Fuchs Titan CARGO 5W- 40
Coolant Qty.	Approx 8.00 Liter (40 to 60% coolant additive)	Engine and vehicle (heating and hoses)
Coolant Additive Specification	Glacelf Auto Supra, VW- G12+ or G13, 40 - 60% coolant content. Or use a finished product (ready mixed).	Important notice:
		Do not mix different engine coolant additive!
		Replace engine coolant and coolant additive every 2 years (including the coolant in the heater and heater hoses)! Never drive without coolant additive, even in warm countries!
		Coolant additives increase the boiling point of the coolant and protect the engine from corrosion.

Citymaster 650 1470.15

9.0.1 Yanmar Engine 3TVN 88C-KHW

Maintanance engine



Change the engine oil and the engine oil filter the first time after 50 operating hours and then every 500 operating hours.

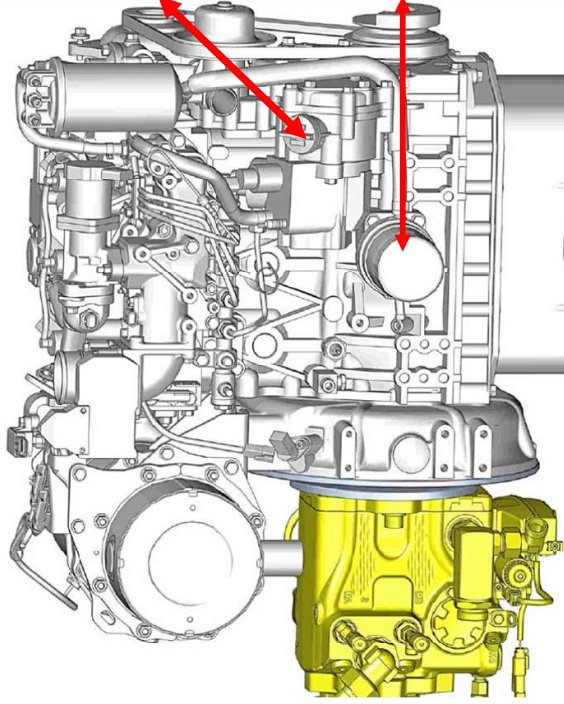

Verschlussdeckel Motoröl
Engine- Oil Filler Cap
PN 01144080

Motoröfilter, Ersatzteilnummer 20 Nm
Engine Oil Filter, PN 01140320

Ölablass-Schraube
Drain Plug (engine oil)
60 Nm
PN 01045000
Dichtung- Gasket
PN 01045010

Motoröl

6,7L 5W 40 Titan Fuchs CARGO

Spezifikation:

ACEA E6, API CJ-4, CAT ECF-3

Engine Oil

6.7 L, 5W- 40, e.g. Fuchs Titan 5W 40

Spezifikation:

ACEA E6, API CJ-4, CAT ECF-3

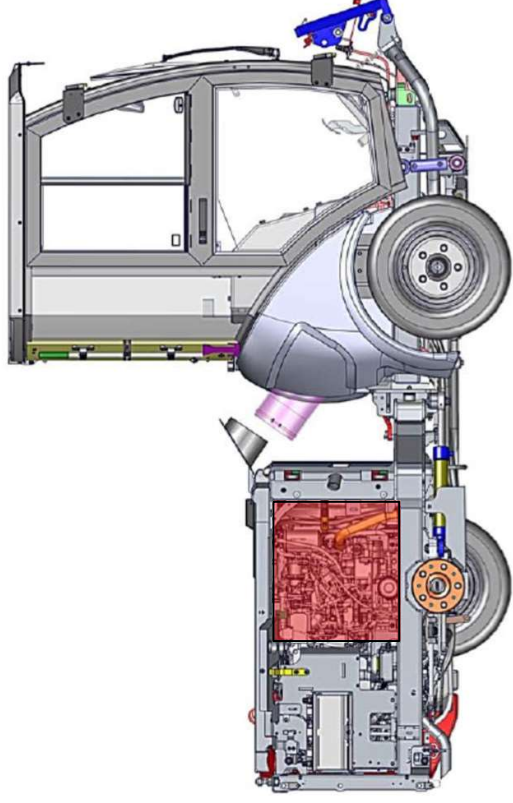

Citymaster 650 1470.15

9.0.1 Yanmar Engine 3TVN 88C-KHW

Maintenance engine



Daily maintenance, check engine oil level and top up if necessary

Checking the engine oil level

Check the engine oil level daily and refill as. Required.

1. Place the vehicle on a level surface and hold it with the parking brake.
2. Switch the engine off and pull out the ignition key. Let the engine cool down.
Note: The circulating engine oil requires a few minutes to flow back to the oil sump.
3. Remove the right side panelling, see page 102.
4. Check the engine oil level with the dip stick Fig. 98-B.
5. The engine oil level should lie between the MAX and MIN mark of the dip stick and may never drop below the MIN mark.
6. Refill engine oil as required and check the engine oil level once again.
Specification: ACEA E6, API CJ-4, CAT ECF-3, Engine oil e.g Titan Cargo 5W-40
Note: The engine oil level must not be above the MAX mark of the dip stick!
7. Reinsert the dip stick.

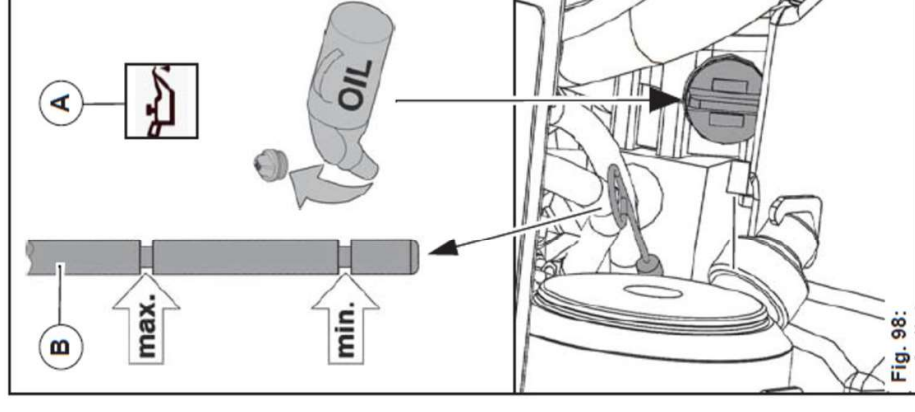

Citymaster 650 1470.15

9.0.1 Yanmar Engine 3TVN 88C-KHW

Maintenance engine



Change the engine oil and the engine oil filter the first time after 50 operating hours and then every 500 operating hours.

Drain off the engine oil with the engine at working temperature.

1. Place the vehicle on a level surface and hold it with the parking brake. Switch the engine off and pull out the ignition key. Let the engine cool down.
Note: The circulating engine oil requires a few minutes to flow back to the oil sump.
2. Place a suitable collecting pan under the drain screw Fig. 62-C.
3. Remove the oil filling cap Fig. 62-A for venting.
4. Unscrew the drain screw and drain off the engine oil completely.
5. Change the engine oil filter Fig. 62-B. Ensure clean sealing surfaces and insert a new gasket.
6. Insert the drain screw with new gasket.
7. Fill engine oil. 6.7 L, 5W-40, e.g. Fuchs Titan 5W 40
Specification: ACEA E6, API CJ-4, CAT ECF-3
8. Start the engine and let it run a short time at slow speed. The engine oil pressure control light must go out after a short time.
9. Switch the engine off, check for oil leaks and check the engine oil level once again.
10. Replace the oil filling cap and the dip stick.

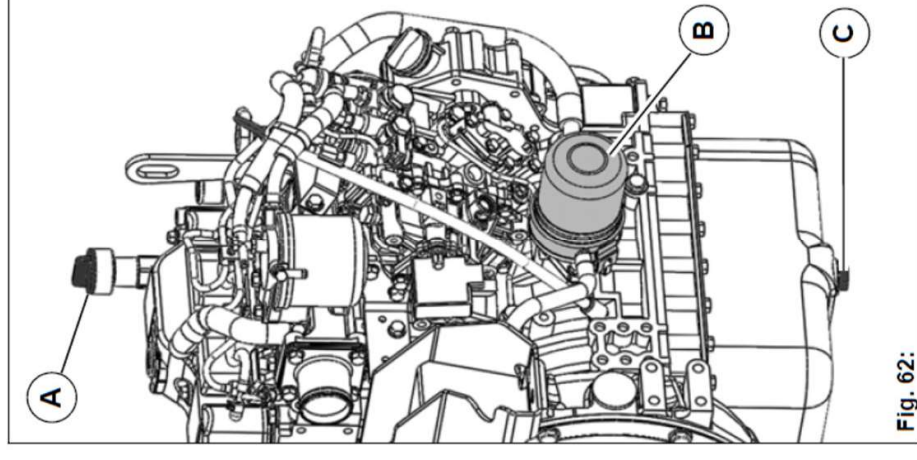

Fig. 62:

Citymaster 650 1470.15

9.0.1 Yanmar Engine 3TVN 88C-KHW

Maintenance engine



Daily maintenance, clean the cooling system

Check the grille sieve and the combination radiator located behind it daily and clean as required.

1. Place the vehicle on a level surface and hold it with the parking brake. Switch the engine off and pull out the ignition key. Let the engine cool down.
2. Open the grille sieve Fig. 100-A with the catch Fig. 100-B.
3. Check the grille sieve and the combination radiator located behind it for contamination and clean as required with compressed air or water jet.

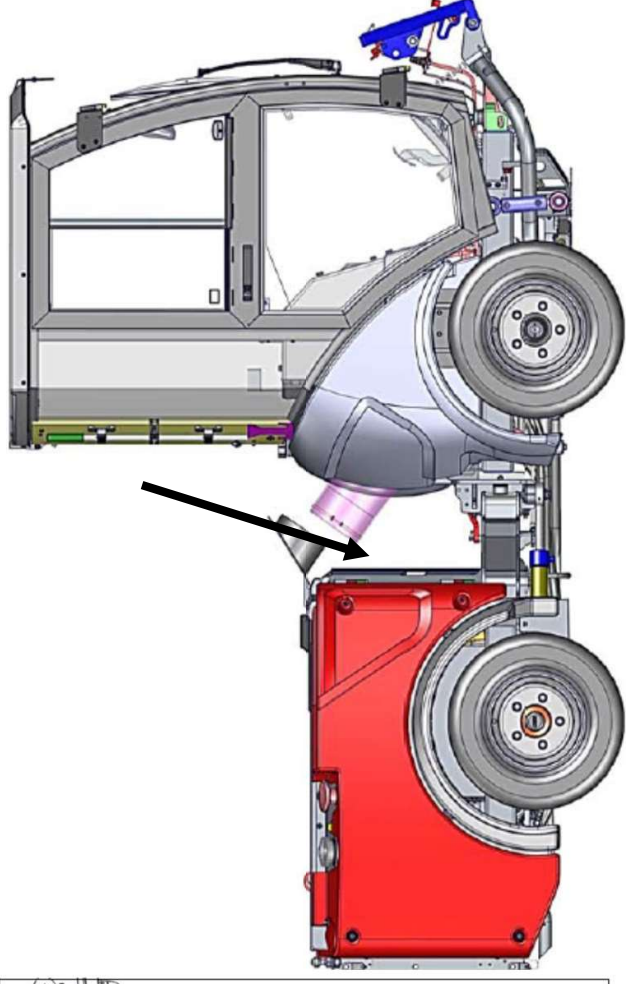
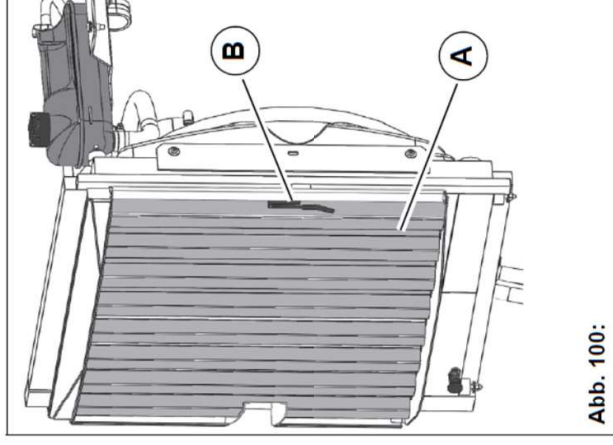

Citymaster 650 1470.15

9.0.1 Yanmar Engine 3TVN 88C-KHW

Maintenance engine



Daily maintenance, check coolant level and refill if required

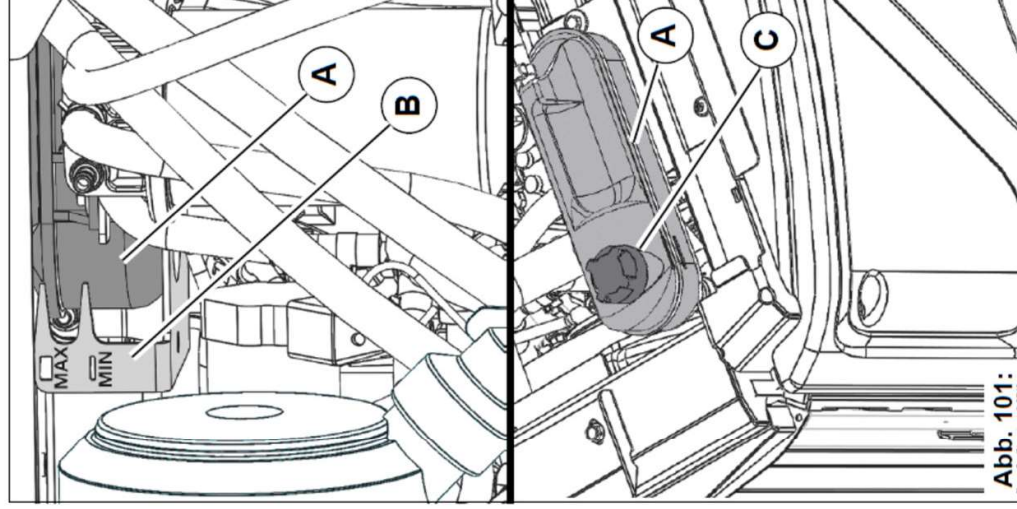

Note: If engine coolant has to be refilled constantly, it is essential to find the cause and eliminate the leak!

1. Place the vehicle on a level surface and hold it with the parking brake. Switch the engine off and pull out the ignition key. Let the engine cool down.
2. Open the right side paneling, see page 102.
3. Check the coolant level. The coolant level of the expansion tank Fig. 101-A must be between the upper and lower mark Fig. 101-B when the engine has cooled down.
4. Unscrew the cap Fig. 101-C carefully step by step from the expansion tank.
5. Refill coolant: Glaceelf Auto Supra. The coolant additive must be at least 40 % and may be a maximum of 60 %. **Never drive without coolant additive! Coolant additives increase the boiling point of the coolant and protect the engine from corrosion!**
6. Check the coolant level, refill once again if necessary.
7. Close the cap again.
8. Replace engine coolant and coolant additive every 2 years (including the coolant in the heater and heater hoses, approx 8,00 Liter)!

Abb. 101:

Citymaster 650 1470.15

9.0.1 Yanmar Engine 3TVN 88C-KHW

Maintenance engine



Weekly maintenance, drain water separator.

Change the insert of the water separator every 500 operating hours (PN 01477140)

Check the water trap Fig. 99-A weekly and drain the condensed water out from the water trap if required.

1. Place the vehicle on a level surface and hold it with the parking brake. Switch the engine off and pull out the ignition key. Let the engine cool down.
2. Remove the right side paneling, see page 102.
3. Place a suitable vessel under the water trap.
4. Close the fuel valve Fig. 99-B by turning it into position Fig. 99-I.
5. Open the drain valve Fig. 99-C. Let the accumulated water drain off.
6. Retighten the drain valve hand-tight.
7. Open the fuel valve again by turning it into position Fig. 99-II.
8. **Change the insert of the water separator every 500 operating hours.**

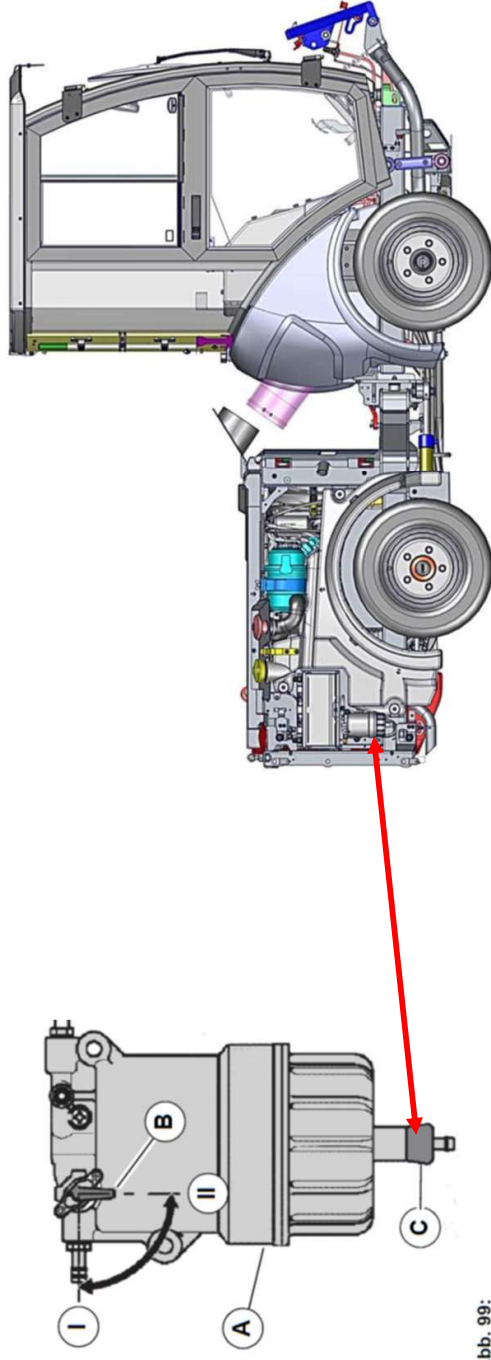

Citymaster 650 1470.15

9.0.1 Yanmar Engine 3TVN 88C-KHW

Maintenance engine



Daily maintenance, check the air filter

Cyclone separator and dust ejection valve.

The air filter has a cyclone separator incorporated in the filter housing. This lengthens the service life of the filter insert. The dust particles separated in the filter housing are ejected from the dust ejection valve Fig. 102-B.

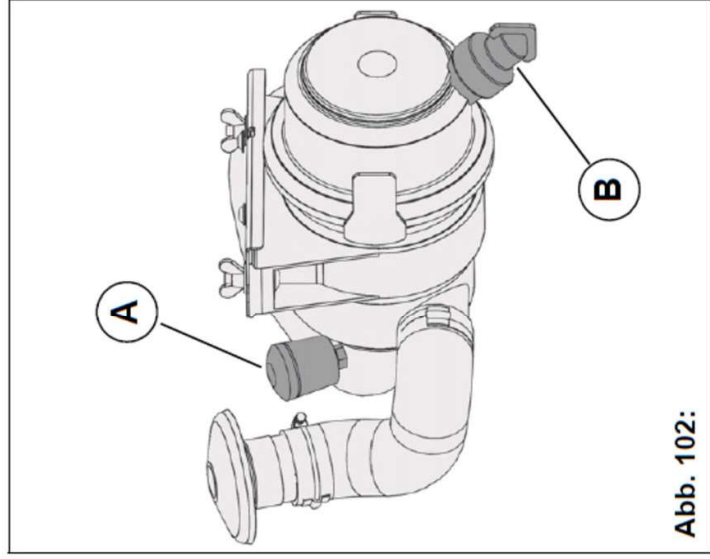

Danger:

Danger of burns from hot parts! Do not touch any parts such as engine block, cooling system and exhaust system during operation and for some time after. Let the engine cool down.

Attention:

- We can assume no liability for cleaned filter inserts. Never let the engine run without a filter insert!
- Only replace the safety cartridge, do not clean it! Never let the engine run without safety cartridge!

Environmental danger:

Ensure safe and environment-conserving disposal of operating and auxiliary materials. Take up spilled operating materials in suitable containers and dispose of them in an environmentally friendly manner.

Citymaster 650 1470.15

9.0.1 Yanmar Engine 3TVN 88C-KHW

Maintenance engine



Change the air filter every 500 operating hours (PN 00682430)

Check the filter insert Fig. 103-D corresponding to the maintenance indicator Fig. 103-A and clean it if required. Change the filter insert at the latest every 500 operating hours.

1. Place the vehicle on a level surface and hold it with the parking brake. Switch the engine off and pull out the ignition key. Let the engine cool down.
2. Open the right side paneling, see page 102.
3. Open the clips Fig. 103-B and remove the filter lid Fig. 103-C.
4. Remove the filter insert Fig. 103-D and clean it from inside to outside carefully with dry compressed air (max. 3 bar) by up and down movements of the compressed air tube.
5. Immediately renew a very dirty or damaged filter insert.
6. Clean the filter housing from the inside.
7. Refit the filter insert.

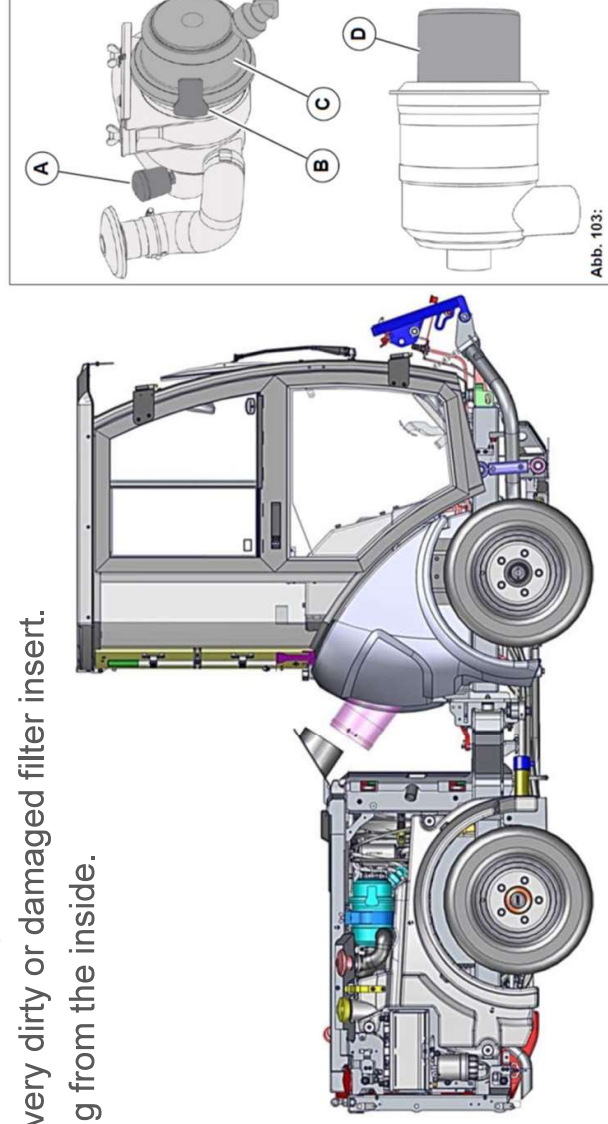

Citymaster 650 1470.15

9.0.1 Yanmar Engine 3TVN 88C-KHW

Maintanance engine



Renew the air filter safety catridge every 1000 operating hours (PN 006882420)

Renew the safety cartridge Fig. 104-A at the latest every 1000 operating hours when changing the filter insert. There is a safety cartridge in the center of the filter insert. The purpose of this safety cartridge is to prevent dirt reaching the suction opening during filter cleaning or filter changing.

1. Place the vehicle on a level surface and hold it with the parking brake. Switch the engine off and pull out the ignition key. Let the engine cool down.
2. Open the right side panelling, see page 102.
3. Open the clips Fig. 103-B and remove the filter lid Fig. 103-C.
4. Remove the filter insert Fig. 103-D.



Abb. 104:

Citymaster 650 1470.15 9.0.1 Yanmar Engine 3TVN 88C-KHW Maintenance engine

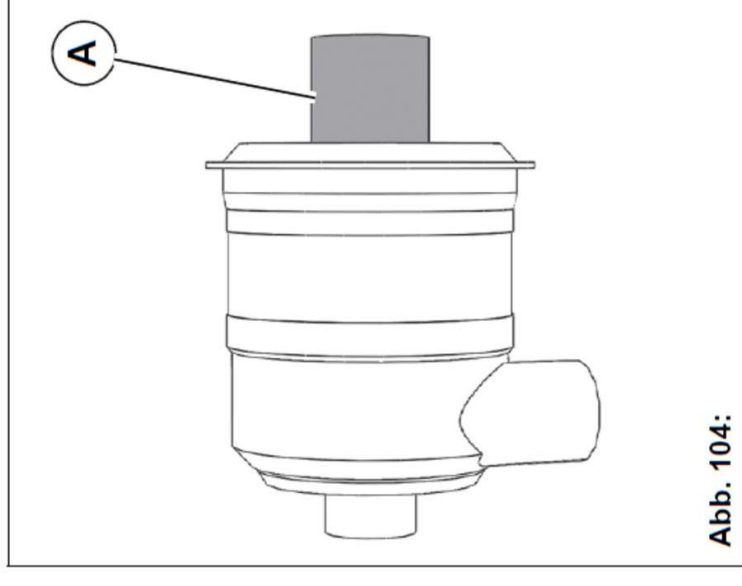

Check valve clearance of the Yanmar engine every 1000 operating hours.
Adjust if necessary

During this maintenance work, check whether the valve caps are set square on the valves or if they have become misaligned due to wear or infiltration of dirt.

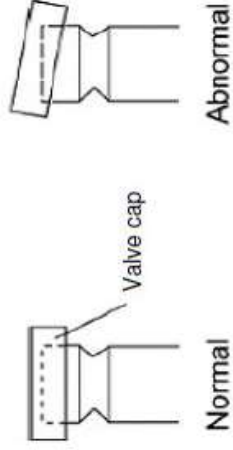
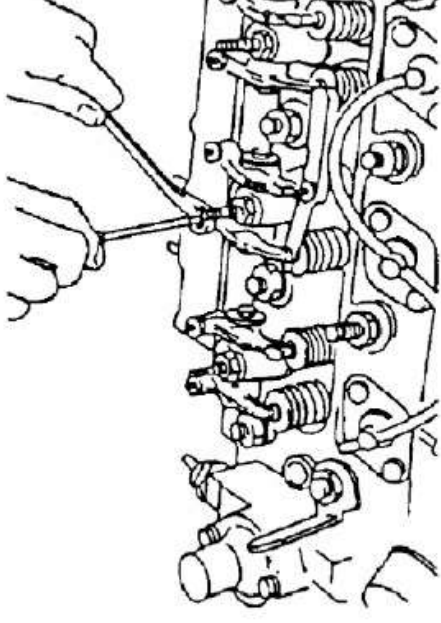
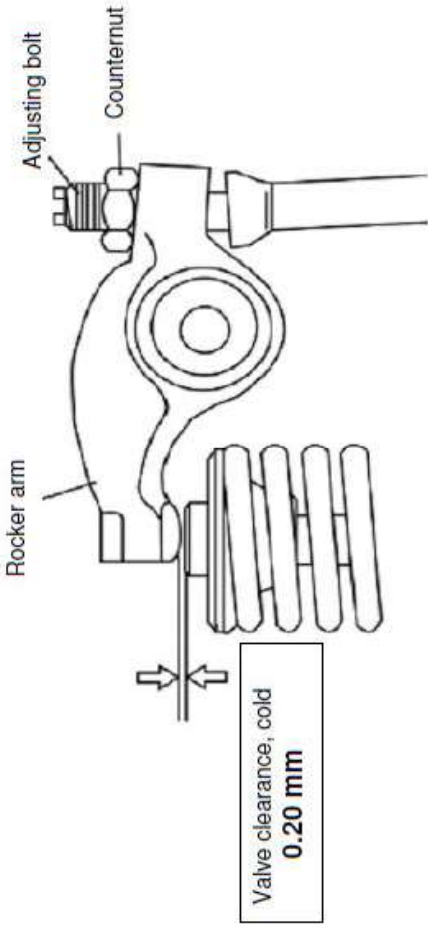

Citymaster 650 1470.15 9.0.1 Yanmar Engine 3TVN 88C-KHW Maintenance engine



Replace diaphragm for crankcase ventilation after 1000 operating hours or at least after 2 years

Complete the following every 1000 operating hours or every 2 years:

- Check whether any oil or condensate has penetrated between the membrane and cover.

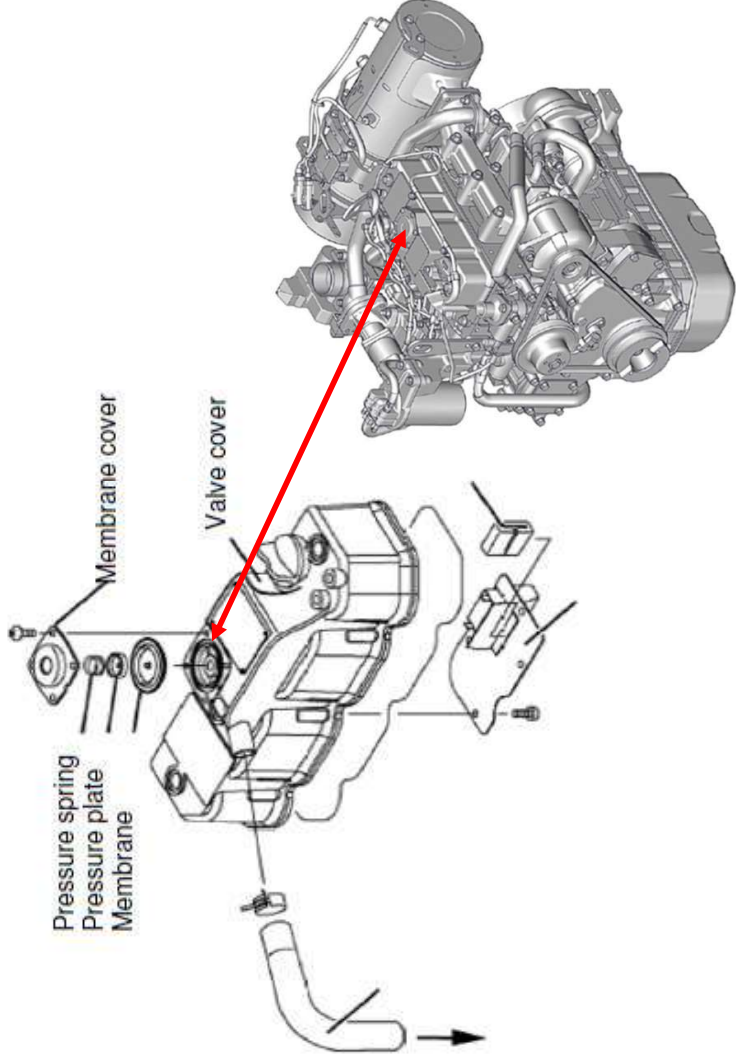

Citymaster 650 1470.15 9.0.1 Yanmar Engine 3TVN 88C-KHW Components engine

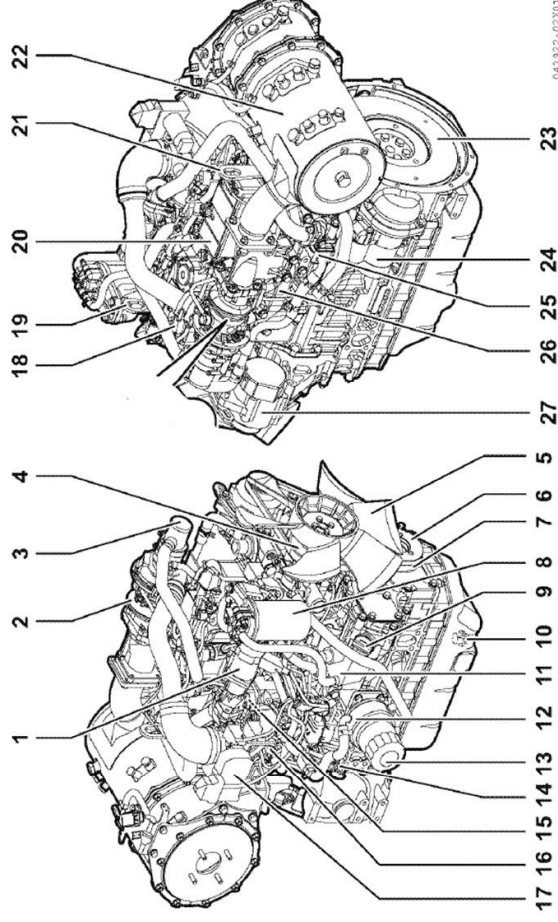

- | | | | |
|----|-------------------------------------|----|--|
| 1 | AGR-Ventil | 15 | Ansaugkrümmer |
| 2 | Turbolade | 16 | Common-Rail |
| 3 | Luftinlasskanal (von Luffilter | 17 | Einlassrosselklappe |
| 4 | Motor Kühlmittelpumpe | 18 | Oberer Einfüllstutzen (Motoröl) |
| 5 | Motor Kühlegebläse | 19 | Aufhängeöse (am Motor Kühlegebläse-Ende) |
| 6 | Kurbelwellenriemenscheibe | 20 | Zylinderkopfabdeckung |
| 7 | Kielriemen | 21 | Aufhängeöse (am Schwungrad-Ende) |
| 8 | Kraftstofffilter | 22 | Dieselpartikelfilter (DPF) |
| 9 | seitlicher Einfüllstutzen (Motoröl) | 23 | Schwungrad |
| 10 | Ablassschraube (Motoröl) | 24 | Starter |
| 11 | Hochdruckpumpe | 25 | AGR-Kühler |
| 12 | Motoröhlkühler | 26 | Auspuffkrümmer |
| 13 | Motorölfilter | 27 | Generator |
| 14 | Messstab (Motoröl) | | |

Citymaster 650 1470.15 9.0.1 Yanmar Engine 3TVN 88C-KHW Components engine

Hako

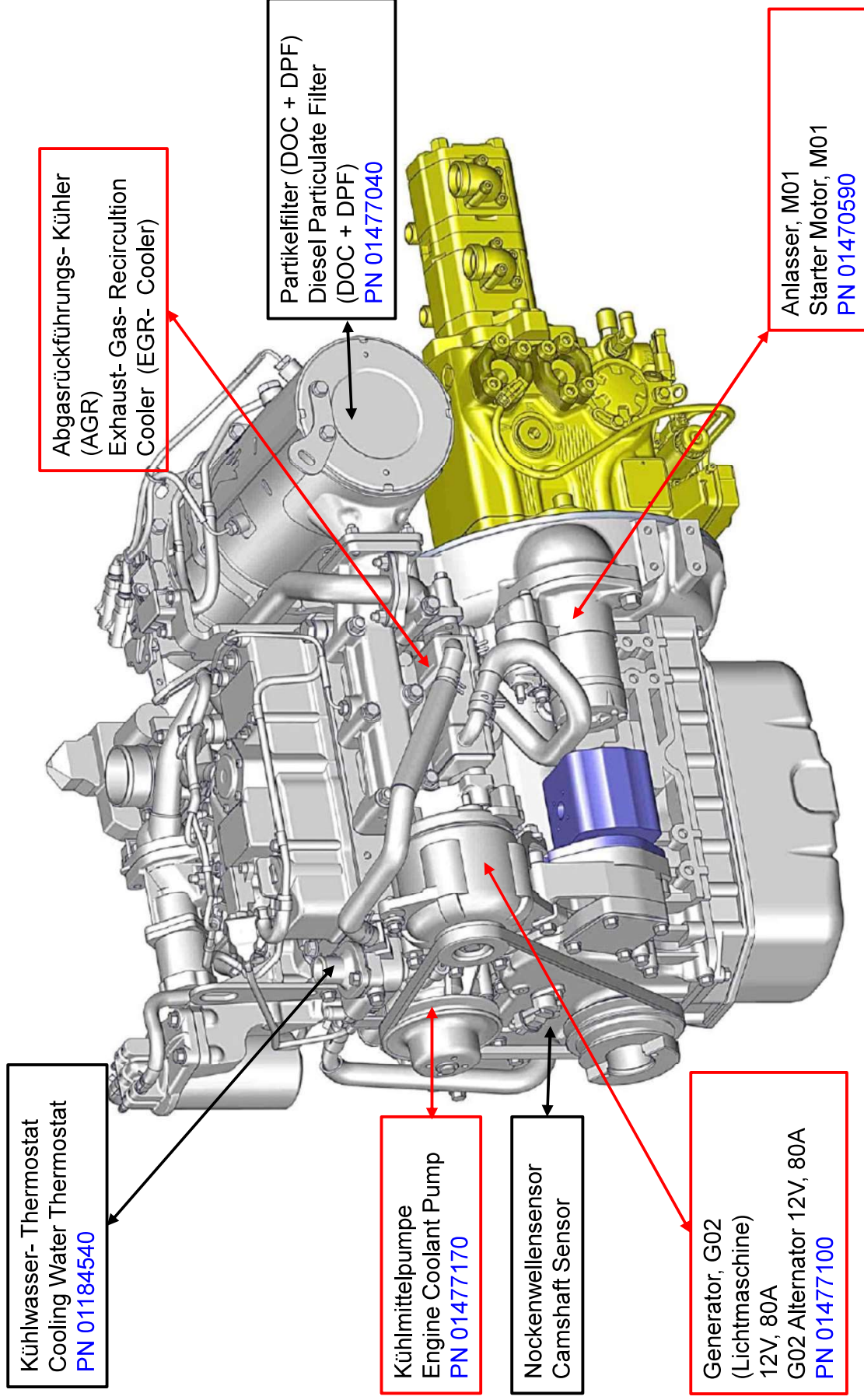

Citymaster 650 1470.15 9.0.1 Yanmar Engine 3TVN 88C-KHW Components engine

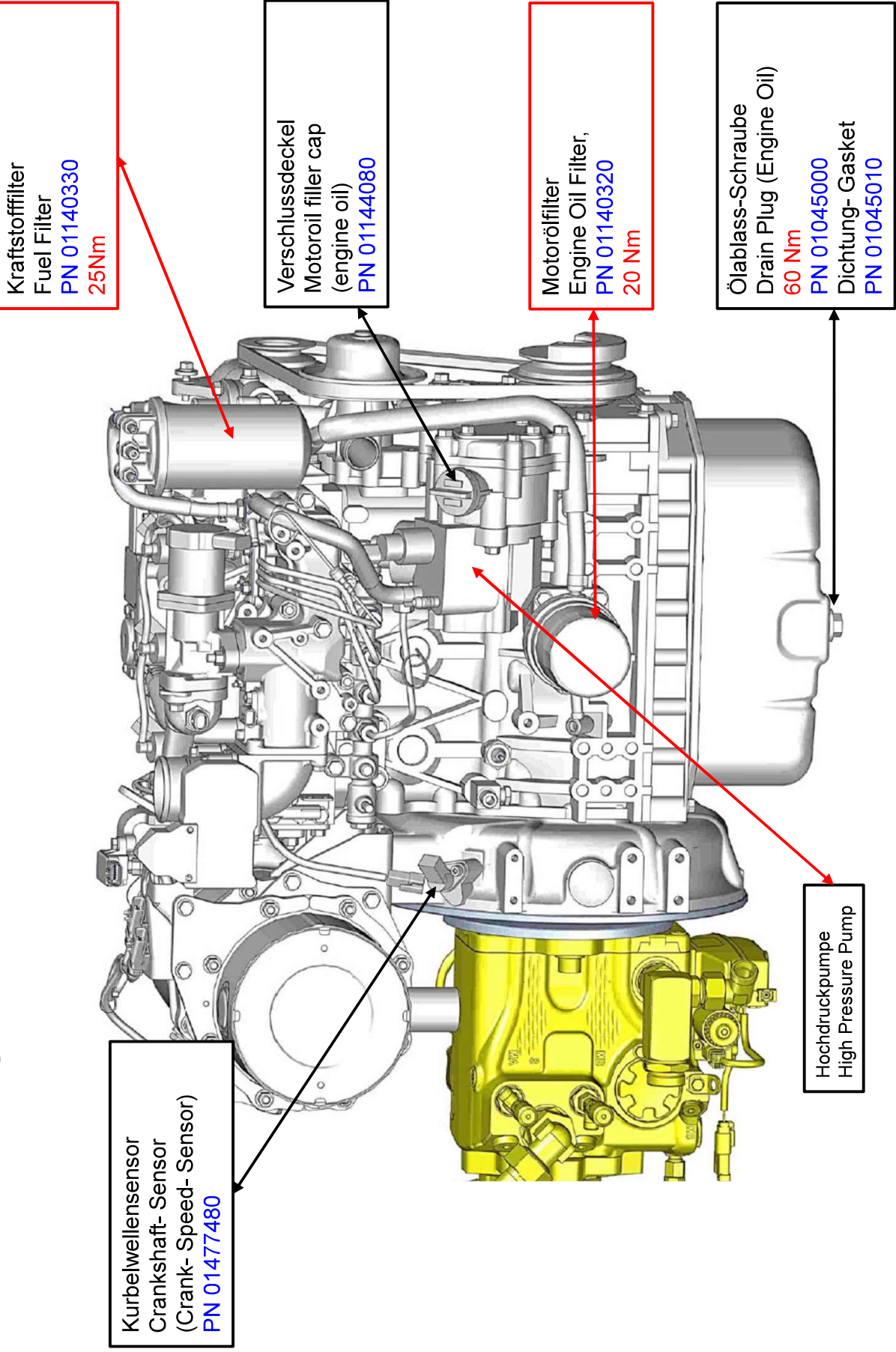

Citymaster 650 1470.15 9.0.1 Yanmar Engine 3TVN 88C-KHW Components engine

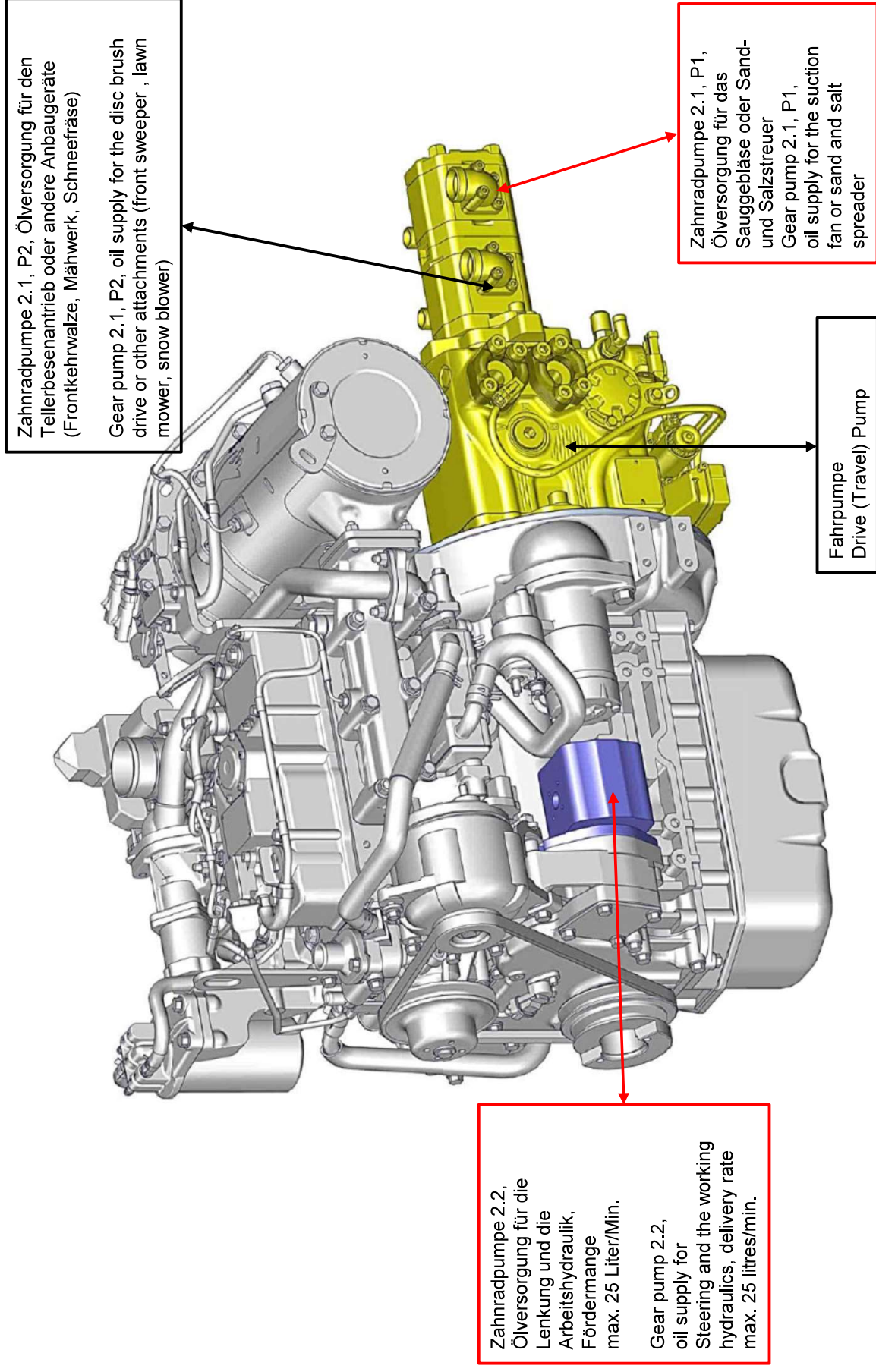

Citymaster 650 1470.15
9.0.1 Yanmar Engine 3TVN 88C-KHW
Components engine

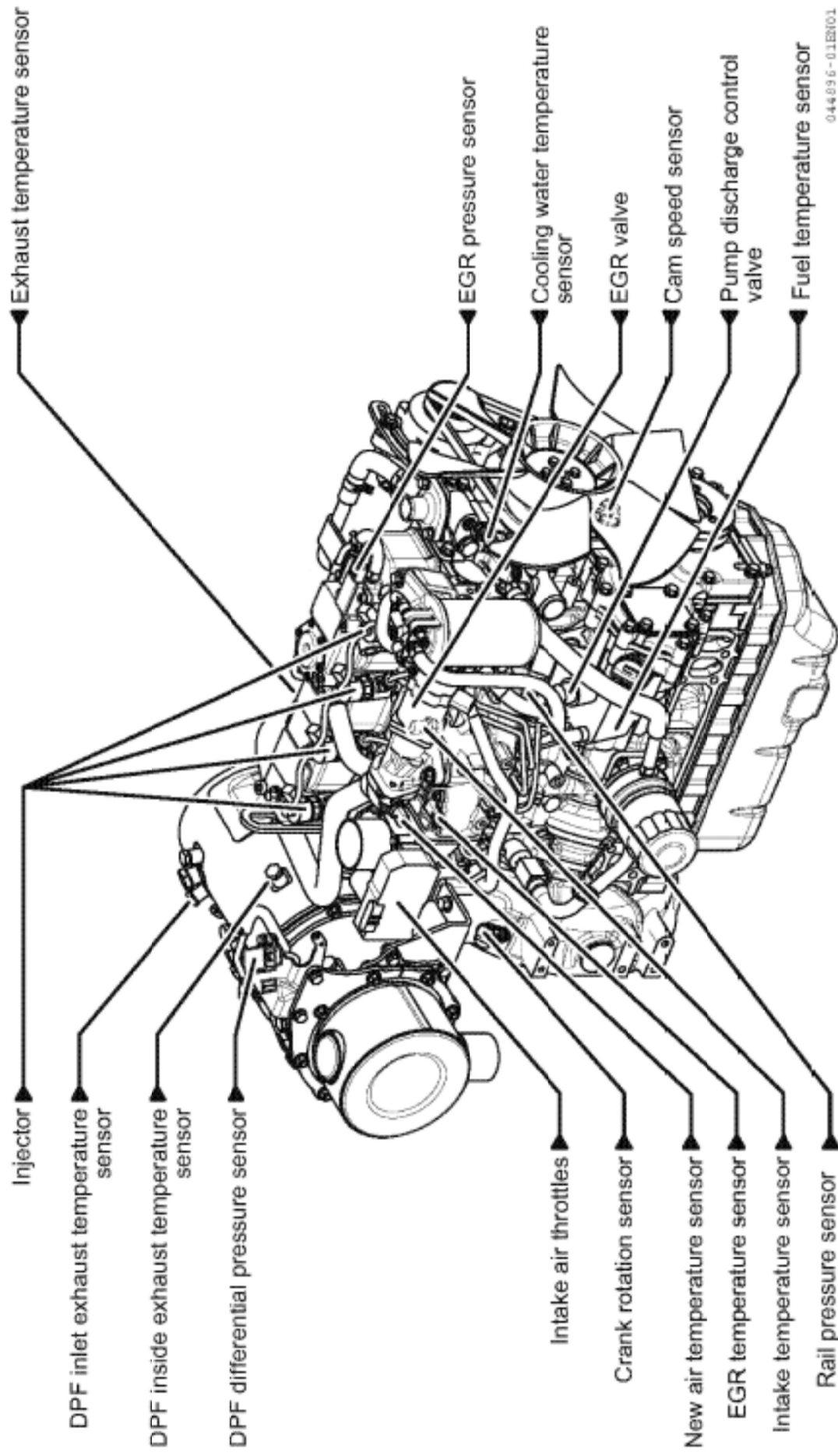

Citymaster 650 1470.15 9.0.1 Yanmar Engine 3TVN 88C-KHW Components engine

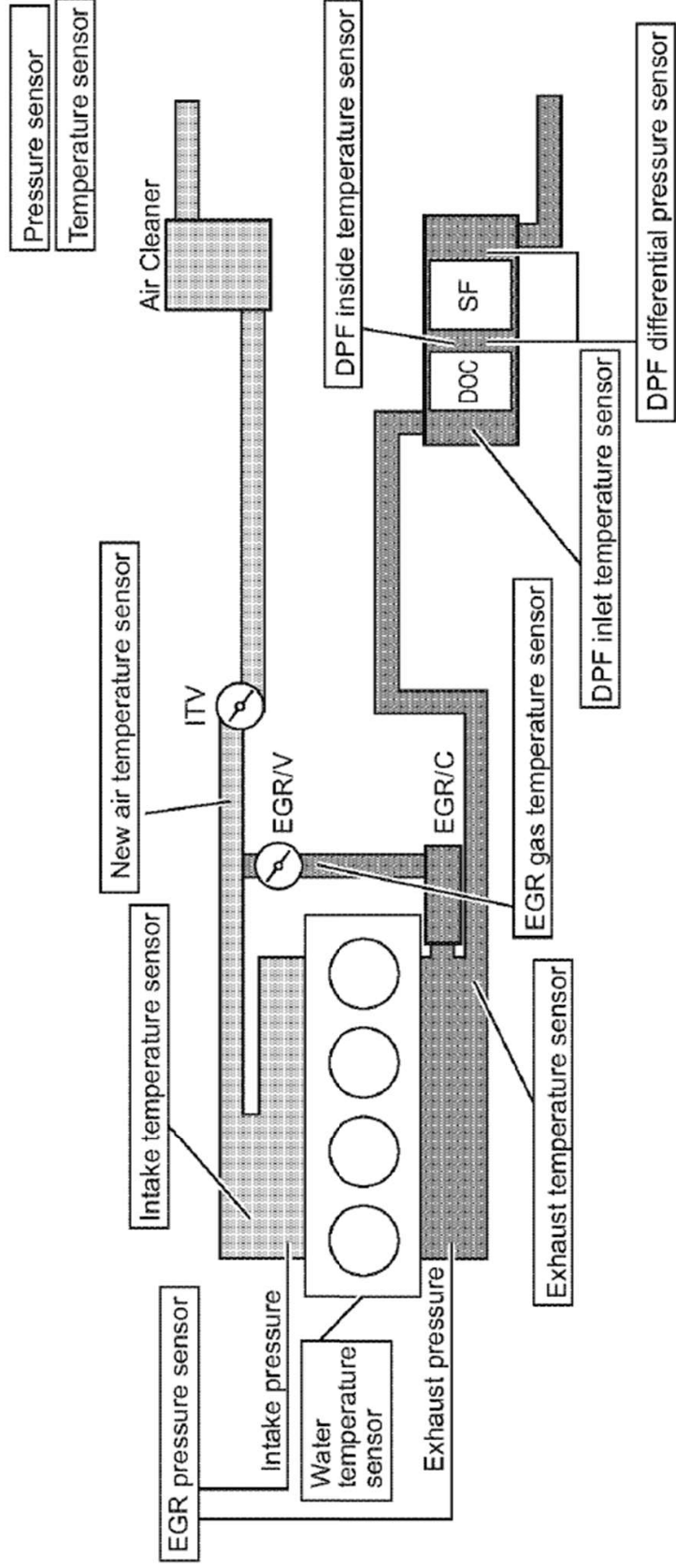

Citymaster 650 1470.15
9.0.1 Yanmar Engine 3TVN 88C-KHW
Components engine



Drosselklappe(Luftansaugseite)
Intake throttle valve
PN 01478310

Partikelfilter (DOC +
DPF) Diesel Particulate
Filter (DOC + DPF)
PN 01477040

Abgasrückführungsventil (AGR)
Exhaust- Gas- Recirculation- Valve
(EGR)
PN 01478420

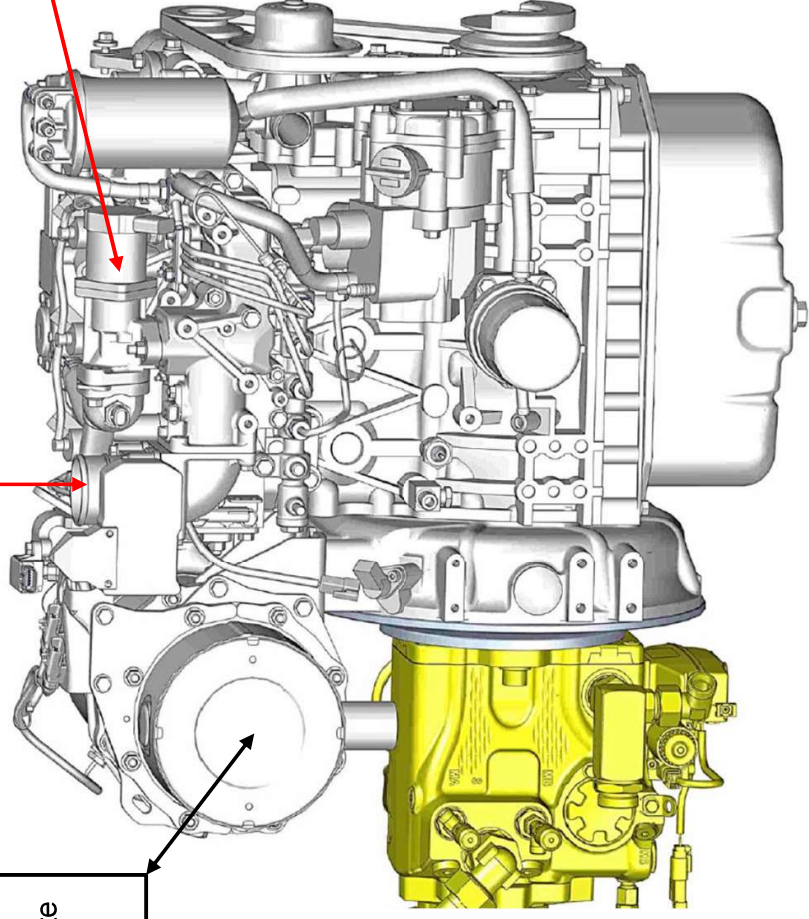

Citymaster 650 1470.15 9.0.1 Yanmar Engine 3TVN 88C-KHW Components engine



DPF-
Differenzdrucksensor
DPF- Differential
Pressure- Sensor
PN 01477240

Temperaturgeber Ansaugluft II
Intake- Temperature- Sensor II
PN 01477160

EGR Drucksensor,
Auswertung des
Differenzdrucks zwischen
Ansaugseite und Abgasseite
PN 01477030
(SPN- Code 1209)

EGR Pressure Sensor,
Measurement of the differential
pressure between intake side
and exhaust side
PN 01477030
(SPN- Code 1209)

Temperaturgeber DPF- Innen
Inside- Exhaust- Temperature-
Sensor DPF (Down Stream)
PN 01477360

Temperaturgeber DPF Eingang
DPF Inlet Exhaust Temperature
Sensor DPF (Up stream)
PN 01477190

Abgastemperaturgeber
Exhaust Temperature Sensor
PN 01478330

Abgasrückführungskühler (AGR)
Exhaust- Gas- Cooler (EGR)
PN 01478370

Nockenwellensensor
Camshaft Sensor
PN 01478840

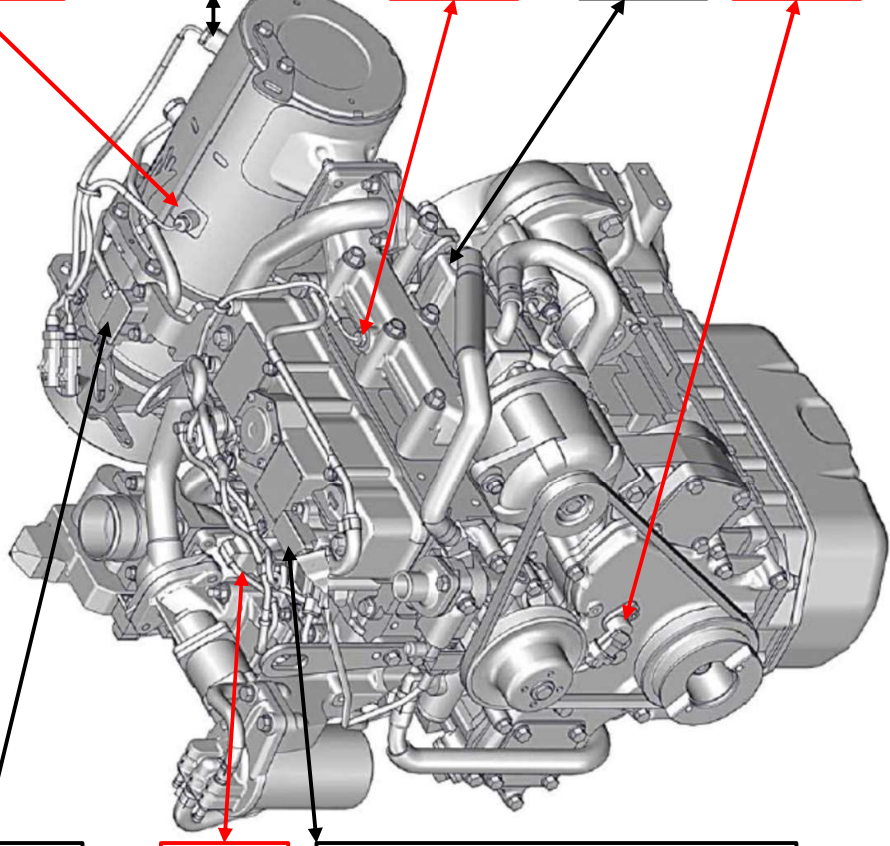

Citymaster 650 1470.15 9.0.1 Yanmar Engine 3TVN 88C-KHW Components engine

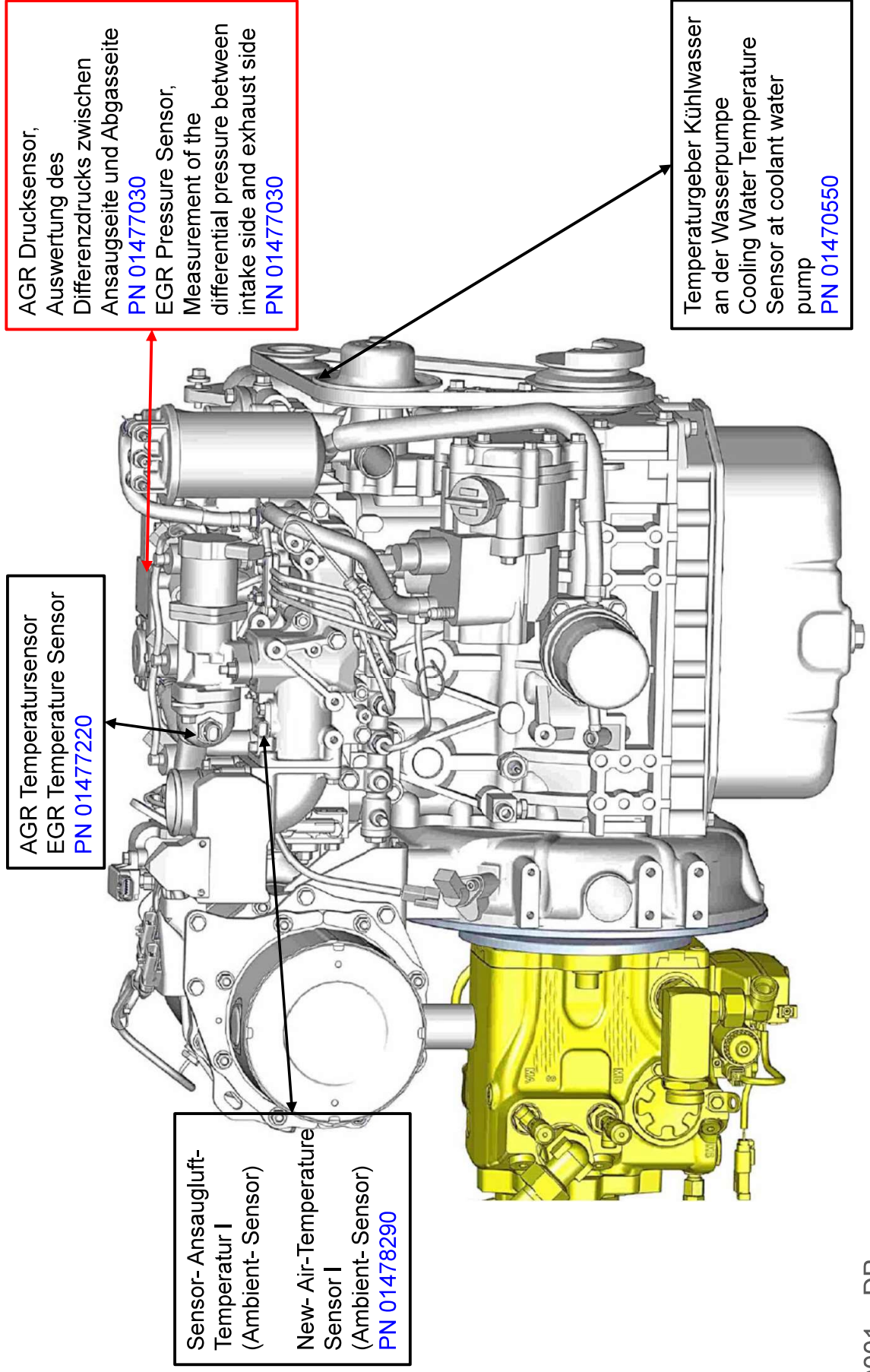

Citymaster 650 1470.15 9.0.1 Yanmar Engine 3TVN 88C-KHW Components engine

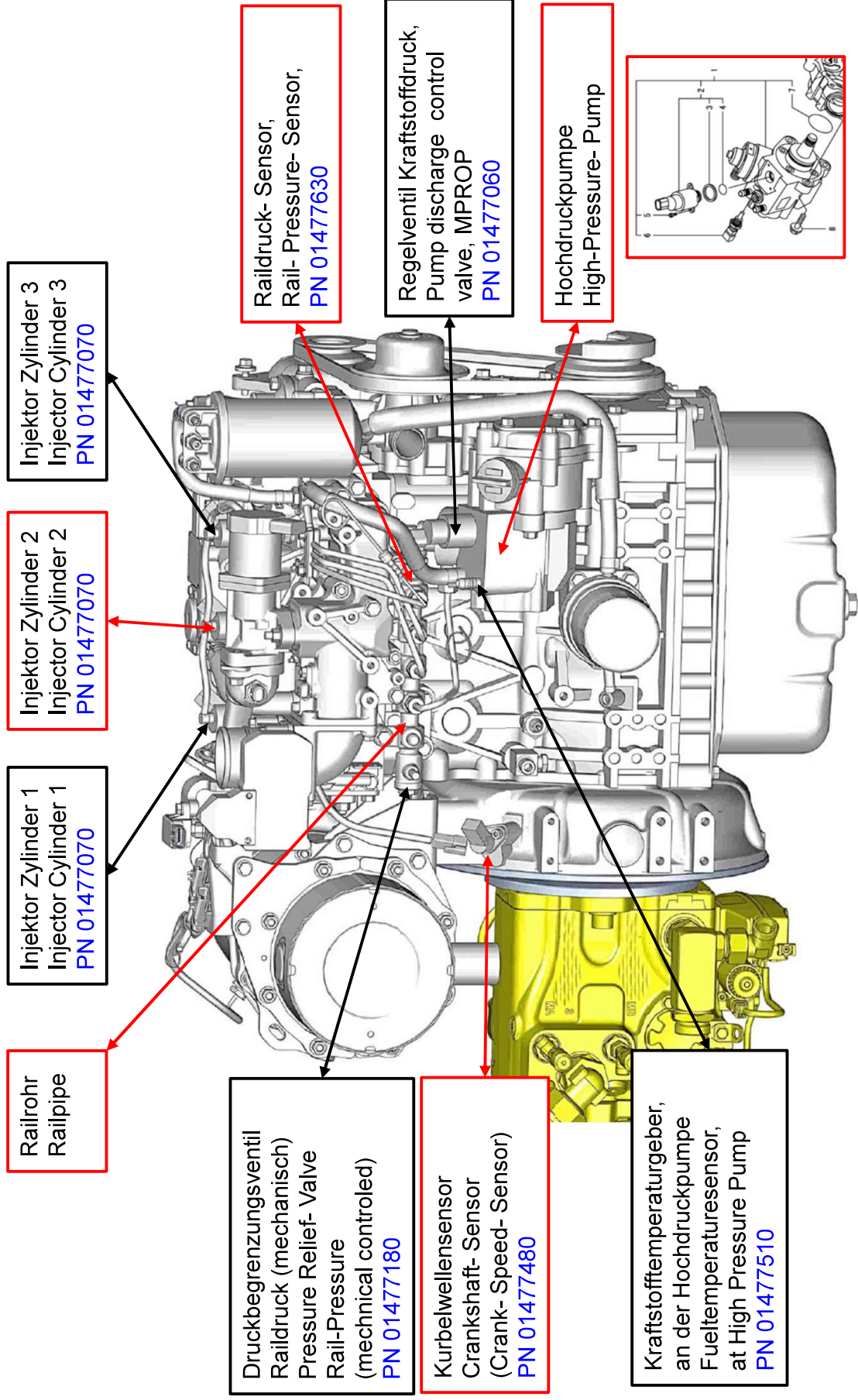

Citymaster 650 1470.15 9.0.1 Yanmar Engine 3TVN 88C-KHW Components engine

Hako

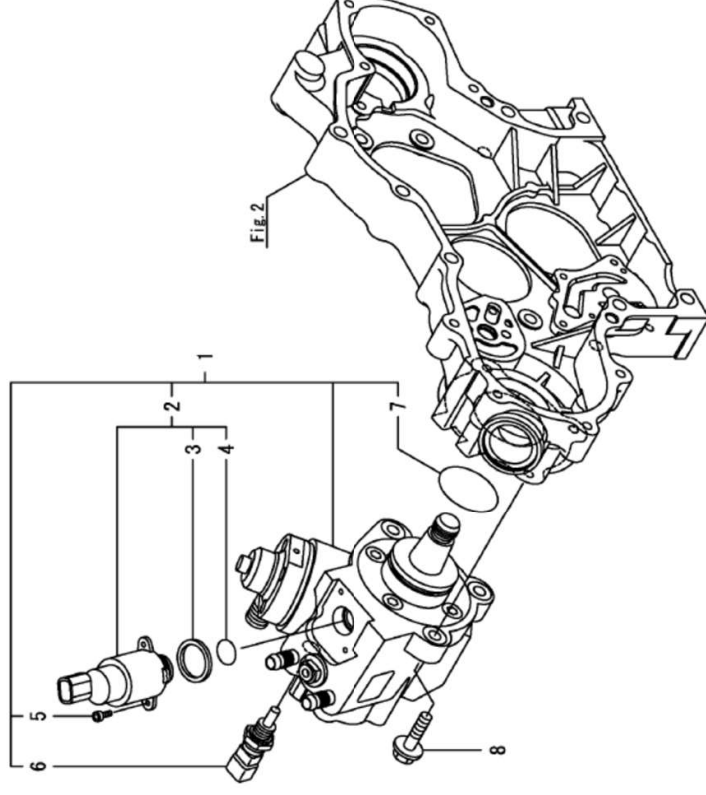

1. Hochdruckpumpe kpl; Yanmar Mat.Nr
1. High-Pressure- Pump Assy; Yanmar PN
2. Regelventil Kraftstoffdruck, MPROF mit Dichtringen;
2. Pump discharge control valve, MPROF with sealings,
6. Kraftstofftemperatur- Geber, an der Hochdruckpumpe ,
6. Fuel- Temperature- Sensor at the High Pressure Pump,

129A00-51000
129A00-51000
PN 01477060
PN 01477060
PN 01477510
PN 01477510

Citymaster 650 1470.15 9.0.1 Yanmar Engine 3TVN 88C-KHW Components engine

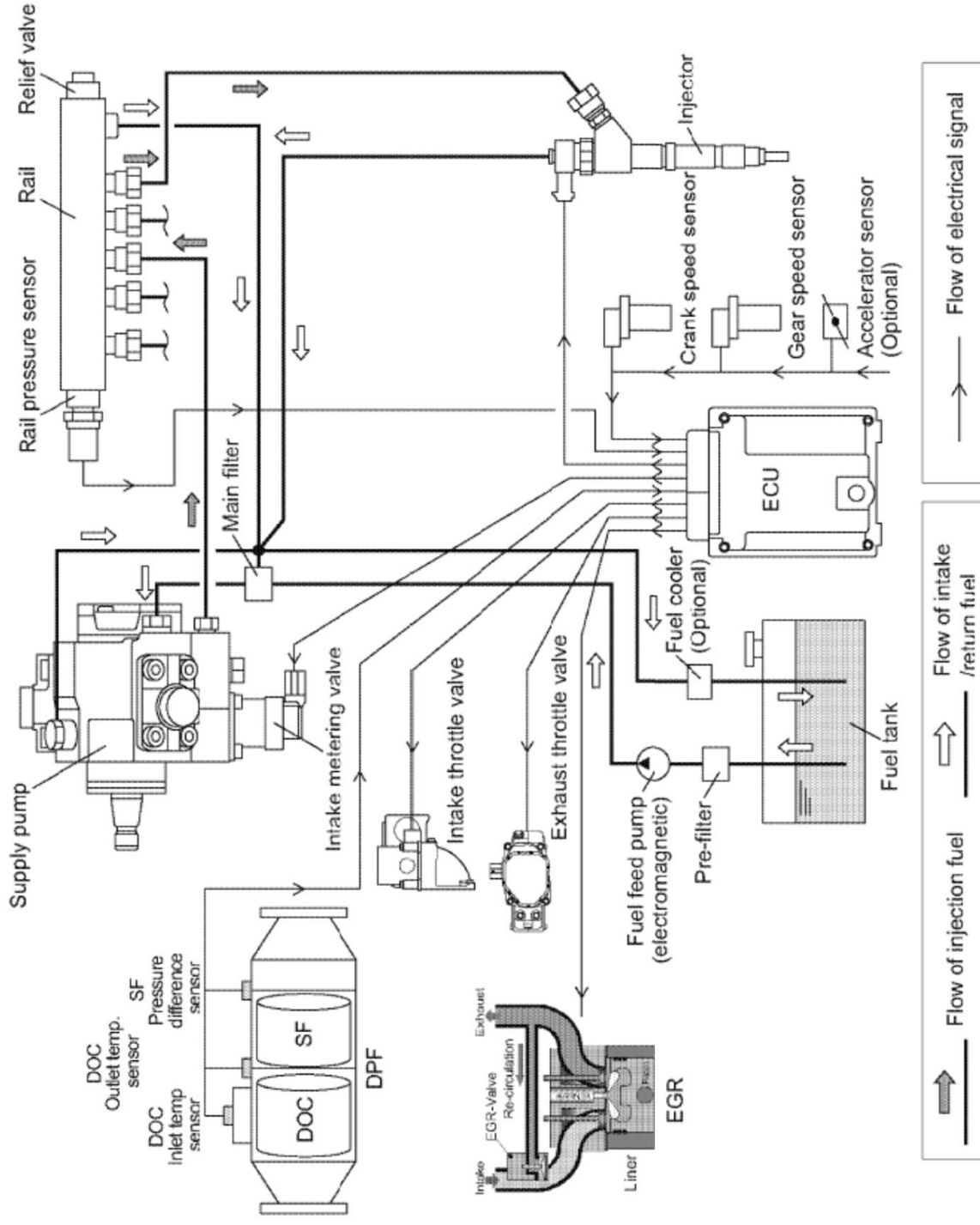

Citymaster 650 1470.15 9.0.1 Yanmar Engine 3TVN 88C-KHW Components engine

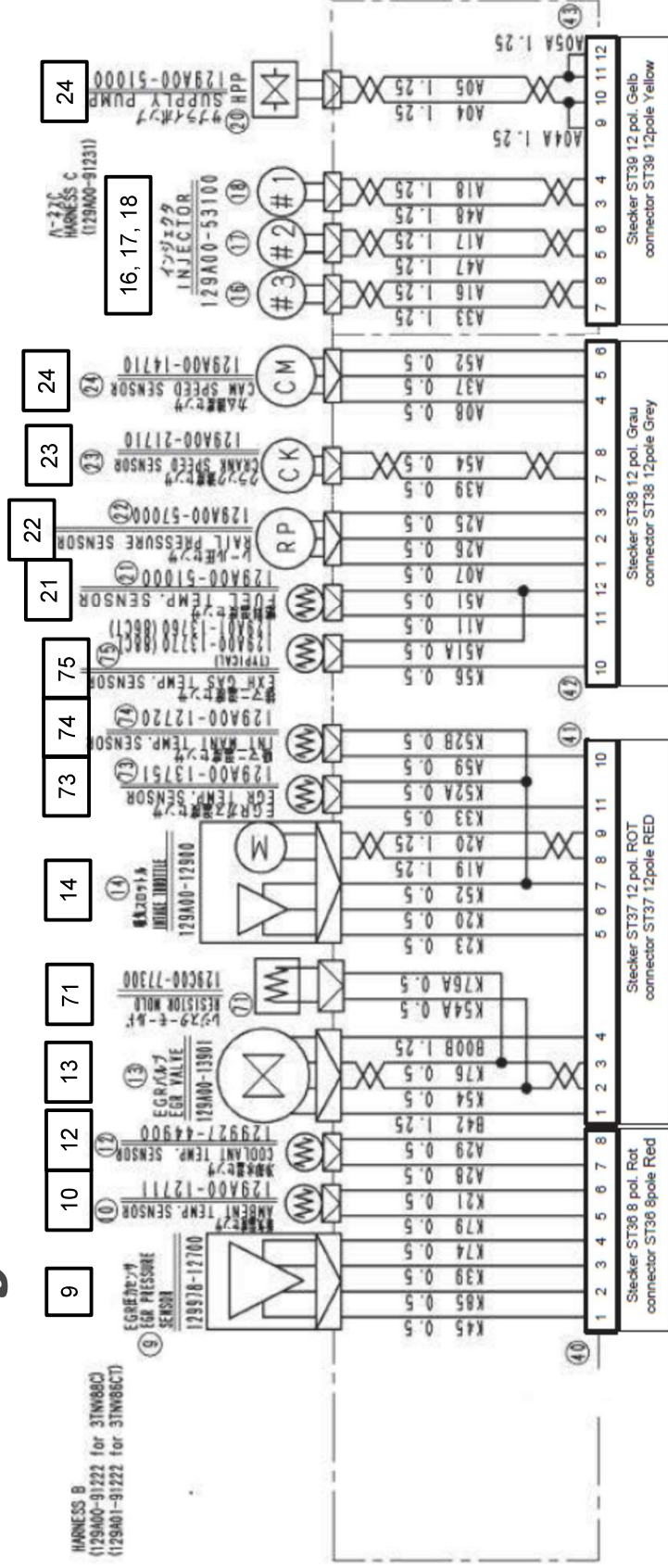

Citymaster 650 1470.15

9.0.1 Yanmar Engine 3TVN 88C-KHW

Components engine



- Yanmar Motorkabelsatz B, mit Stecker ST36 (rot) und ST37 (rot) und ST38 (grau), Hako Ersatzteilnummer 01477130
- Yanmar Engine- Harness B with plug ST 36 (red), St 37 (red) und ST38 (grey), Hako- Spare Part Number 01477130
- Yanmar Motorkabelsatz C, ST39 (gelb), Hako Ersatzteilnummer 01477200
- Yanmar Engine- Harness B with plug ST38 (yellow), Hako- Spare Part Number 01477200

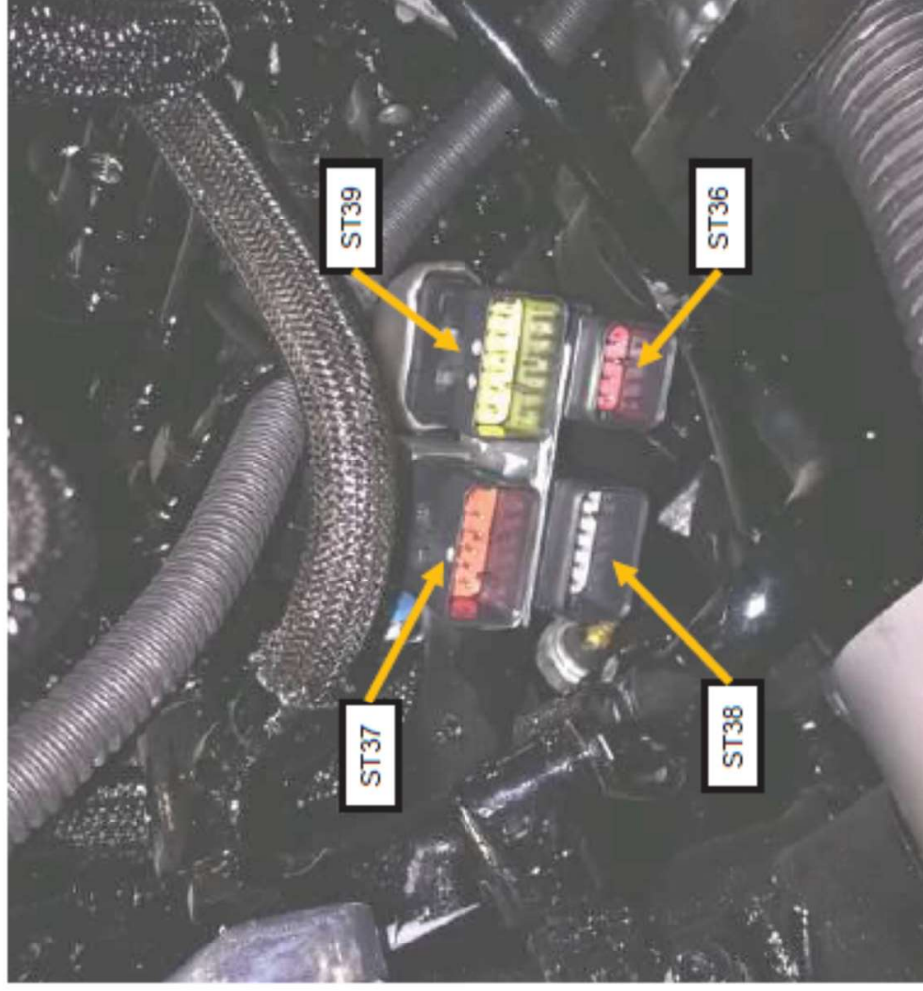

Citymaster 650 1470.15

9.0.1 Yanmar Engine 3TVN 88C-KHW

Engine regeneration



The vehicle is equipped with a diesel particulate filter. The diesel particulate filter (DPF) filters soot particles from the exhaust gas. During regular regeneration, the accumulated soot particles are burned at high temperatures. Depending on how high the soot concentration in the diesel particulate filter is, the following modes are provided by the engine control unit:

- Automatic regeneration
- Manual regeneration

Automatic regeneration:

The automatic regeneration starts automatically and runs smoothly during work. This mode is used for normal soot concentration. During regeneration, it is warned of hot exhaust gases. The diesel particulate filter (hot exhaust gases) information symbol Fig. 90-B appears in the multifunction display. If the current situation does not allow it, automatic regeneration can also be disabled. However, the lock should be removed as soon as possible to prevent damage to the diesel particulate filter!

- Use the turn-push knob Fig. 90-69 to switch from the normal view to the configuration menu and call up the diesel particulate filter setting sub-menu.
- Use the turn-push knob to set the value Fig. 90-D to ON. The diesel particulate filter (regeneration locked) information symbol Fig. 90-C appears in the multifunction display.



Citymaster 650 1470.15

9.0.1 Yanmar Engine 3TVN 88C-KHW

Engine regeneration



Manual regeneration:

The manual regeneration must be started by the operator. This mode is used for increased soot concentration. The diesel particulate filter (regeneration required) information symbol Fig. 91-A appears in the multifunction display.

- Use the turn-push knob Fig. 90-69 to switch from the normal view to the configuration menu and call up the diesel particulate filter menu.
- The following conditions must be fulfilled for regeneration:
 - The parking brake has been applied
 - The engine is switched on and transport mode has been selected
 - Temperature > 10 ° C
 - Regeneration lock has been switched off
- If all the conditions have been fulfilled, the symbols Fig. 91-B light up green. The regeneration can be started. Use the turn-push knob to select the START symbol Fig. 91-C. During regeneration, the progress is indicated by a yellow bar. If the exhaust gas temperatures rise, the diesel particulate filter (hot exhaust gases) information symbol Fig. 91-D appears. A green bar is displayed once regeneration has been completed.
- Use the turn-push knob to select the EXIT symbol and switch back to the normal view.

Note: For uninterrupted manual regeneration, note the following:

- Do not change the speed
- Leave the accelerator pedals in neutral position
- Do not release the parking brake
- Do not use the vehicle during manual regeneration Non-observance leads to premature termination of regeneration.



Citymaster 650 1470.15
9.0.1 Yanmar Engine 3TVN 88C-KHW
DOC and Soot filter

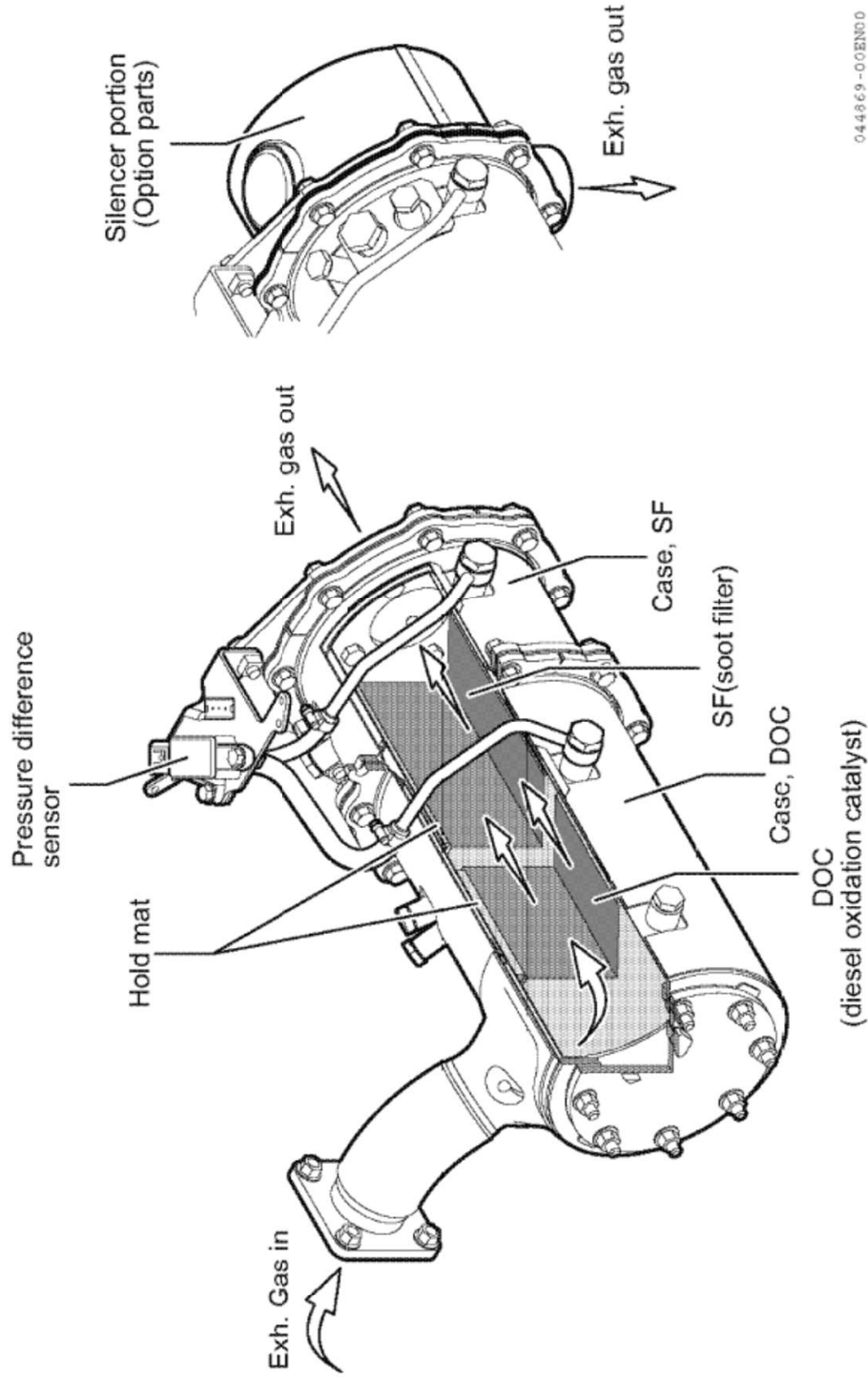

Citymaster 650 1470.15

9.0.1 Yanmar Engine 3TVN 88C-KHW



Component/feature	Description
Engine controller (ECU)	<p>To be precise, E-ECU is an abbreviation for Engine Electronic Control Unit.</p> <p>By controlling the fuel injection timing, injection volume, injection pressure, and number of injection in accordance with the target speed indication entered from the accelerator sensor, the controller adjusts the engine speed and power.</p> <p>Depending on the above-mentioned speed and power, the controller controls the EGR opening. Also, the controller acts as the key station of the application function.</p>
Fuel pump (supply pump)	The fuel pump supplies fuel to the common rail.
Common rail	The common rail stores the compressed high-pressure fuel from the supply pump and distributes fuel to the injector in each cylinder.
Fuel injector	The Fuel Injectors the high-pressure fuel from the rail to the engine combustion room after receiving a signal from the ECU in the most appropriate injection timing, injection volume, injection ratio, number of injection and spray condition.
EGR valve	Controls the exhaust gas recirculation flow rate depending on the engine speed/load signals from the ECU. It is installed on the top of the exhaust manifold.
Diesel Particulate Filter (DPF)	The Diesel Particulate Filter (DPF) consists of the diesel oxidation catalyst (DOC) and the soot filter (SF). It is a device to prevent the discharge of particulate matter (PM) by oxidizing the hazardous constituent with the DOC and collecting the PM in the exhaust gas with the SF.
Intake throttle valve	The intake throttle adjusts the amount of intake air in the engine and controls the exhaust temperature to assist the DPF regeneration.

Citymaster 650 1470.15 9.0.1 Yanmar Engine 3TVN 88C-KHW



Component/feature	Description
SMARTASSIST-DIRECT (SA-D)	<p>Allows the operator to troubleshoot the cause of a problem based on detailed information regarding the defects occurring in the ECU internal control information.</p> <p>The SMARTASSIST-DIRECT can also be used for data maintenance tasks including ECU internal programming, mapping and adjustment values. For more details, see <i>Troubleshooting of Electronic Control System on page 93.</i></p>
Option for service	
Engine coolant temperature sensor	<p>Allows the fuel injection volume and ERG to be controlled in engine cold-start conditions.</p>
On-glow control (preheat)	<p>At cold start, when the key switch is set to the ON position, the system automatically energizes the glow plug relay and keeps it energized for particular amount of time depending on the engine coolant temperature. (Maximum 15 seconds)</p> <p>The preheat indicator lights up while the relay is being energized. When the indicator goes out, turn the key switch to the "START" position to start the engine.</p>

Citymaster 650 1470.15 9.0.1 Yanmar Engine 3TVN 88C-KHW Injektor

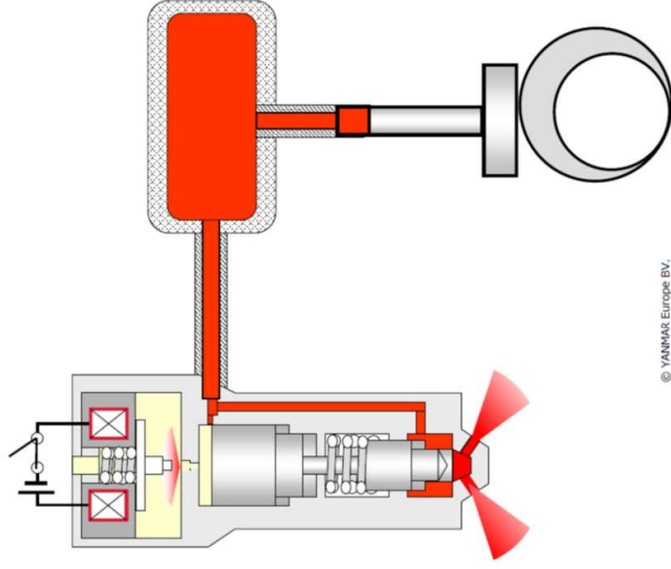

© YANMAR Europe BV.

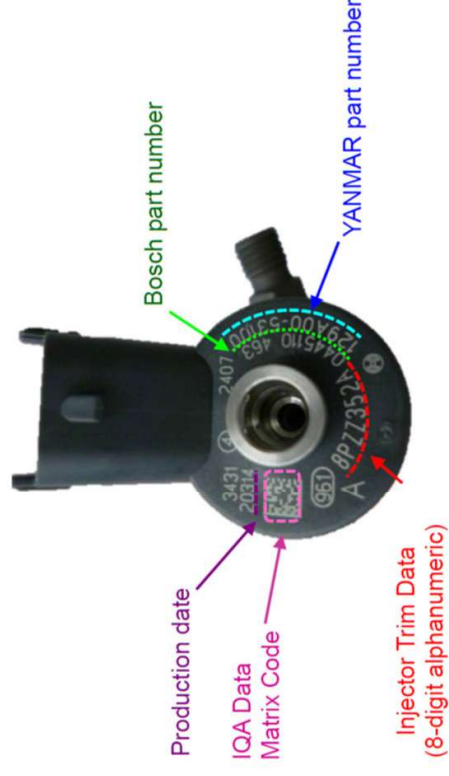

Speed Sensor

